

Unlocking the value in
conveyor systems with

Automatic RFID tunnels

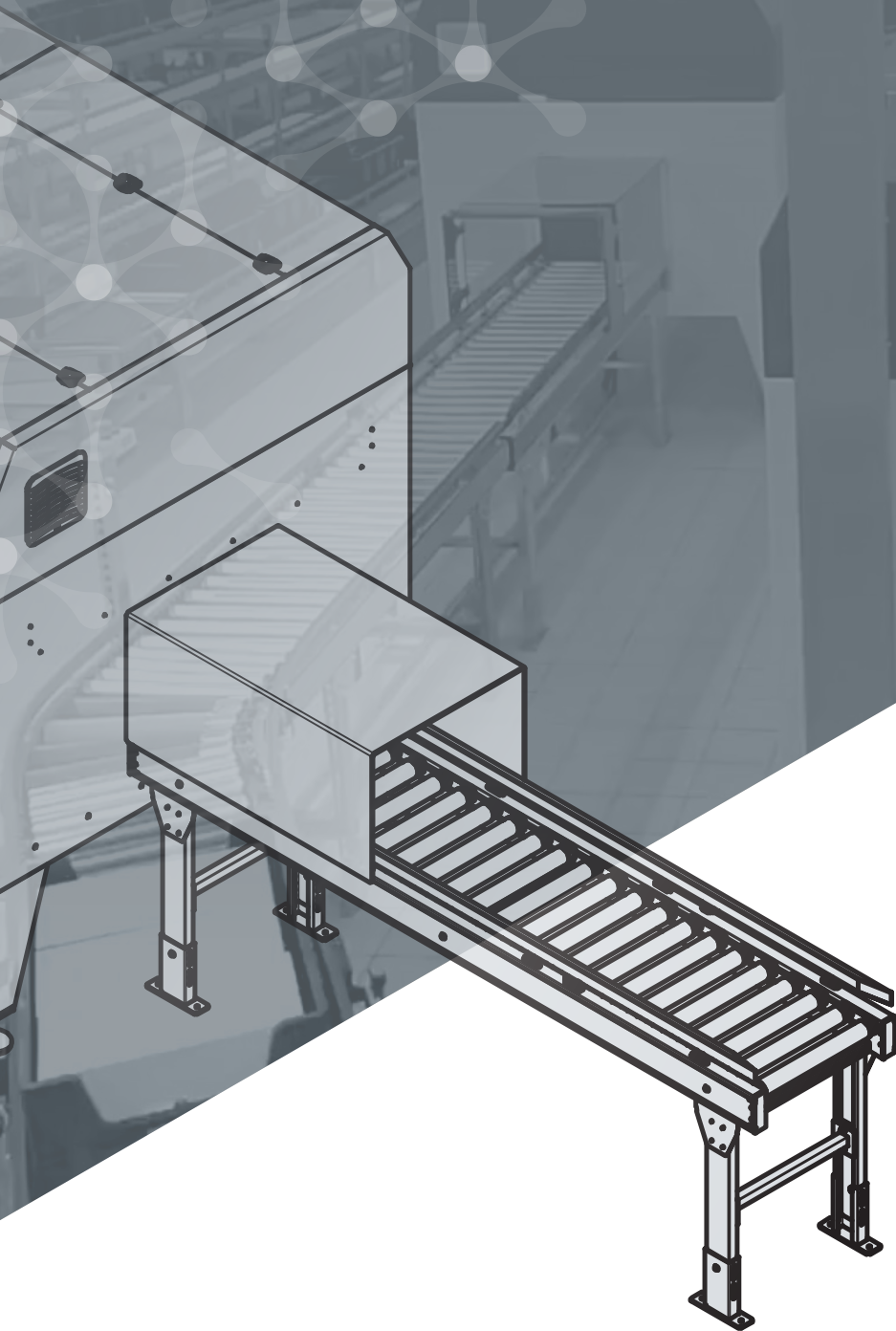

muRata
INNOVATOR IN ELECTRONICS

Automatic RFID tunnel

The RFID tunnel provides fast and accurate automatic reading of RFID tagged items moving in boxes through the conveyor system in the manufacturing plants or in the distribution and logistics centres.

It automatically compares the scanned products with a list of expected tags and accordingly provides green light to proceed only for the boxes that match the list. The boxes with issues or errors are automatically diverted into a manual check station.

The tunnel can work either as a stand alone device or it can be easily integrated with an existing automatic material handling system. Integration occurs both on a physical layer between conveyors, and on a logical layer based on PLCs and RFID reads, to effectively manage idle times, box identification, queues, diversions and other events.

The RFID Tunnel enables:

Inbound/outbound flows optimization and accuracy increase

By optimizing the product flow and increasing the inventory accuracy, manufacturing plants and distribution centres can significantly increase their operations' efficiency, as well as their service level, while also reducing labour.

Grey Market Fighting

As each tag is uniquely identified and linked to its recipient, it is possible to obtain precise information on the single item's market of origin. It is therefore easy to track the source of any parallel market and prevent fraud and counterfeiting.

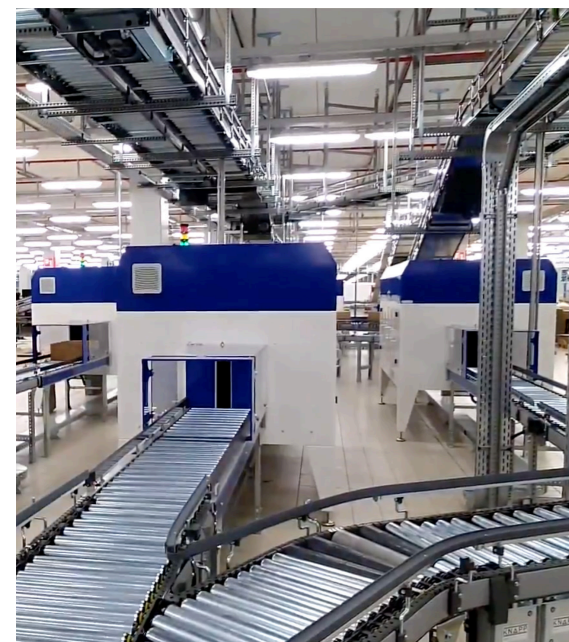

High performance:

The tunnel has top level performances: up to 100+ items per box - throughput 900+ boxes per hour.

High accuracy:

Perfect for very fast reading of inbound/outbound flows and for inventory counts: accuracy up to 99.95%.

Fully automatic:

The automatic sliding doors isolate the reading area to optimize accuracy compared to standard RFID tunnels.

Versatile & Flexible:

Can be used in all steps of the supply chain from manufacturing to logistics.

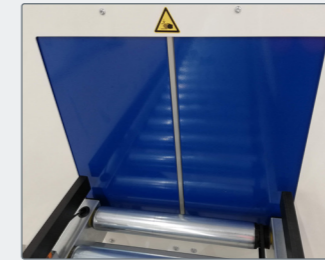
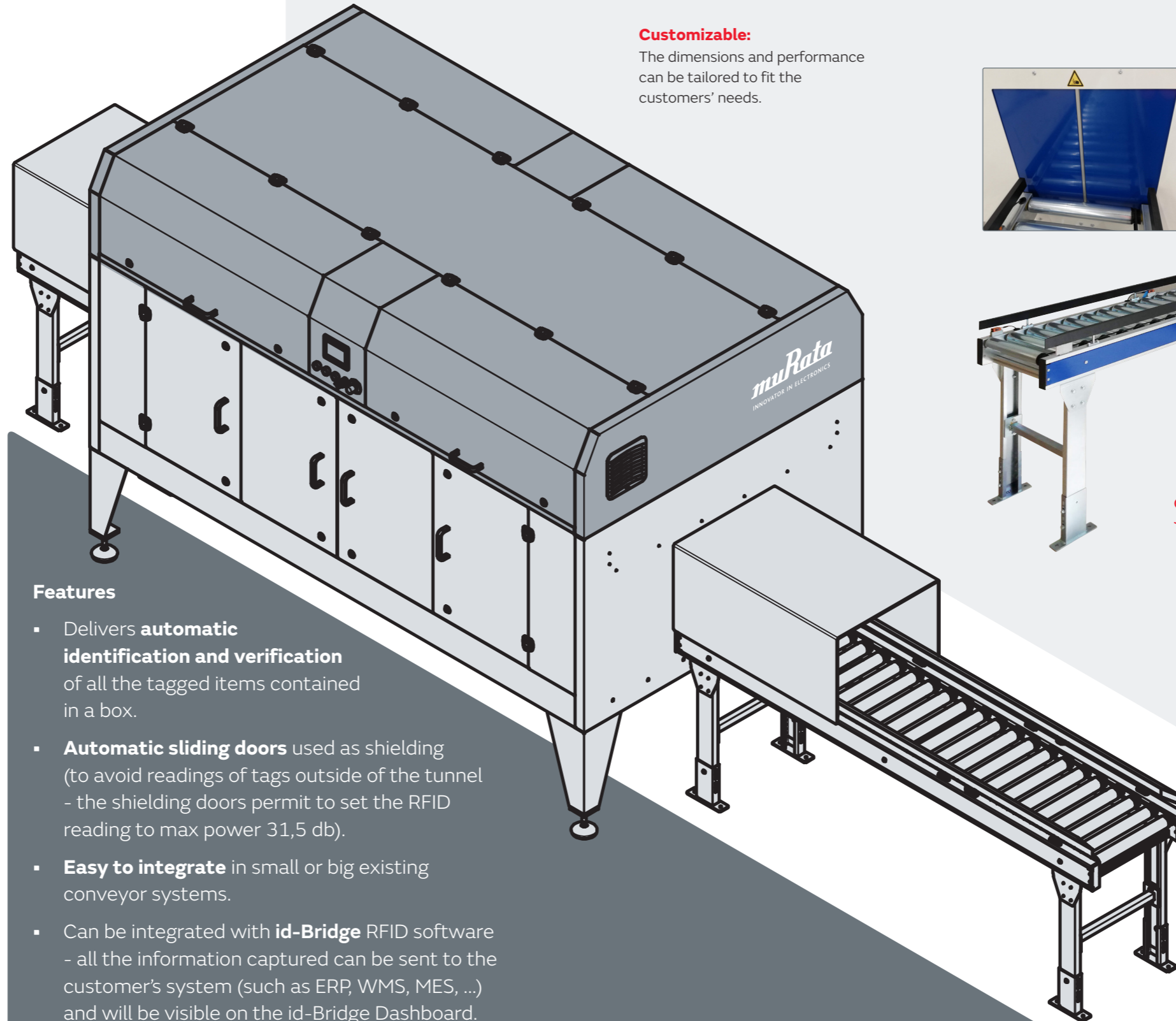

Scan over 900 boxes
(100 items/box)
per hour with
99.95% accuracy

Features

- Delivers **automatic identification and verification** of all the tagged items contained in a box.
- **Automatic sliding doors** used as shielding (to avoid readings of tags outside of the tunnel - the shielding doors permit to set the RFID reading to max power 31,5 db).
- **Easy to integrate** in small or big existing conveyor systems.
- Can be integrated with **id-Bridge** RFID software - all the information captured can be sent to the customer's system (such as ERP, WMS, MES, ...) and will be visible on the id-Bridge Dashboard.
- **Can be customized** to fit different production environments and conveyor systems.

About Murata

Murata is a global leader in the design, manufacture and supply of advanced electronic materials, leading-edge electronic components and multi-functional, high-density modules. Murata innovations can be found in a wide range of applications from mobile phones to home appliances, and automotive applications to energy management systems and healthcare devices.

www.murata.com

muRata
INNOVATOR IN ELECTRONICS

Murata ID Solutions
Via G. Di Vittorio, 46
43044 - Lemignano di Collecchio (PR) Italy
P.IVA IT02334000342

Tel: +39 0521 831205
email: info@id-solutions.it

go.murata.com/eu-rfid

